

SPECIAL

PRECISION SOLAR SIMULATION

SPECIAL



Spirale 3

POWERED WITH
 **ATLAS**
MATERIAL TESTING SOLUTIONS

Climats
a schunk company

A STEP FURTHER®

"Specifically designed for the optimal irradiation of various samples"

Climats' commitments in terms of expertise and innovation resulted in the designing of a new simulation solution that meets our customers' requirements.

As, in our customers' applications, a wide range of products are subject to solar simulation such as polymer/plastic and metallic automotive components, defense and aerospace devices, and several electronic boards & systems, the reliability of the raw material, coatings and assemblies must be tested with chambers able to reproduce the most severe and extreme conditions.

To meet these standards, Climats' Precision Solar Simulation chambers are equipped with our reliable premium features combined with the best modular solar irradiation unit, powered with Atlas Sunlight technology.

Test standards examples

MIL STD 810 procedure 2 ACTINIC :	Aerospace and Defense industries
IEC 60068-2-5 :	Electronic industry
CEI 61215 & CEI 61646 -BBA Class :	Photovoltaic industry
DIN 75220, DR106 :	Automotive industry

A wide range of test standards can be achieved upon request.

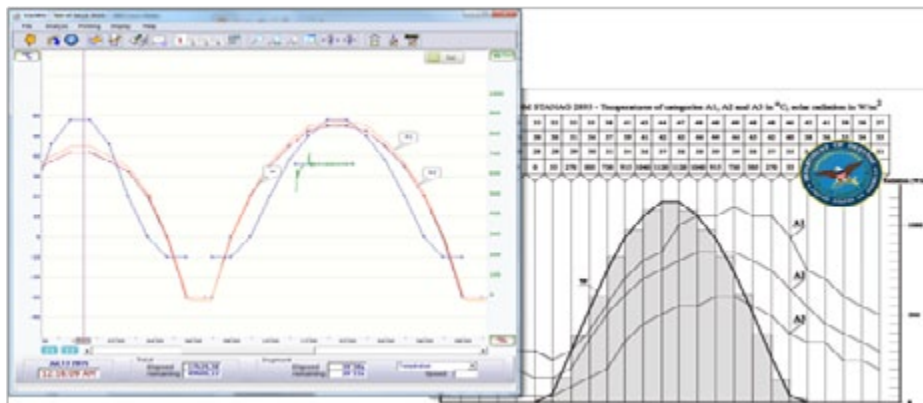

Spirale3 test record perfectly fit with the Mil-Std 810 standard

Spirale 3 Reference piloting system

Reliable and accurate, SPIRALE 3 is the reference software solution, controlling over 4,000 environmental test chambers and test benches worldwide.



Developed by Climats' engineers for ergonomic and efficient management of your machine, SPIRALE 3 enables you to enjoy all its usual premium features combined with a specific Sunlight simulation interface.

Temperature, Humidity & Irradiation are thus independently controlled and programmed in only one piloting and regulating software, to perfectly fit operators' needs.

TEMPERATURE TEST PERFORMANCE

With radiation

-20°C / +100°C

Without radiation

-40°C / +120°C

HUMIDITY TEST PERFORMANCE

With radiation

10%RH / 80%RH on the range +15°C / +80°C

Without radiation

10%RH / 90%RH on the range +10°C / +90°C

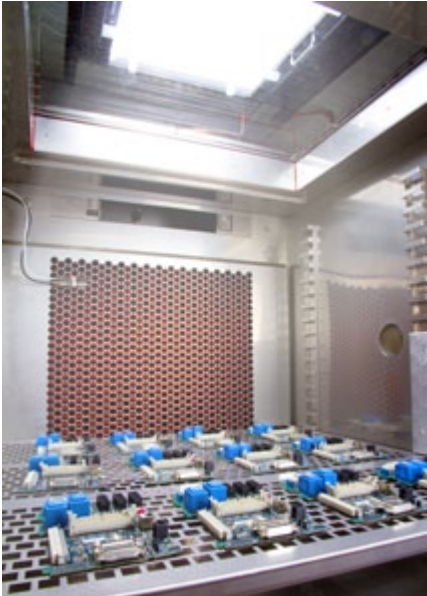

WORKING INTERNAL VOLUME

Our precision solar simulation chambers are available on internal volumes based on Climats EXCAL wide range of chambers.

Larger and customized chambers are available upon request !

According to the large number of existing test standards and configurations, Climats studies all project case by case to deliver the most suitable and unique solution that meets your requirements.

Please send us your test specifications to receive a quotation !

SUNLIGHT TECHNOLOGY

Sunlight unit

Indoor & outdoor Total solar spectrum, HMI Lamp with MHG Technology, powered by ATLAS®.

The metal halide lamps (HMI type lamps) used in our precision solar chamber generate an electric arc with very high brightness and high localized radiation intensity.

Our technology is engineered to simulate all exposure conditions on Earth with irradiance level up to 1200W / m², keeping the sun spectrum.

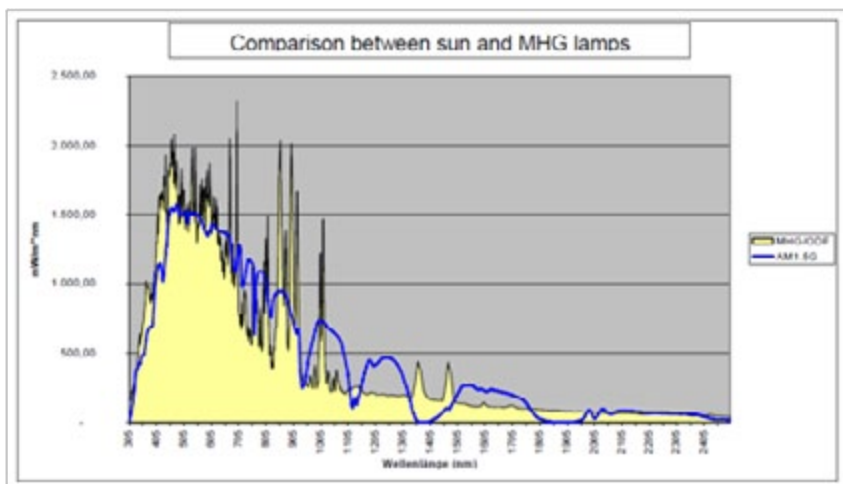

POWERED WITH

ATLAS
MATERIAL TESTING SOLUTIONS



Convenient access

Climats has designed the most ergonomic solution allowing the best intensive experience with an industrial & high tech equipment.

A smooth bearing rail system, easily manageable by one operator, offers a very simple access to the sunlight unit for the installation of outdoor/indoor additional glass/filters and for general maintenance.



Outdoor Filters

In order to adapt the spectrum, the sunlight unit can host different filters to reach inside/outside conditions and meet all the test specifications requested by your industrial sector.

Neutral wire mesh filters are delivered with the system. A set of 4 different wire meshes is dedicated to each lamp. This system gives you the possibility to optimize the overall irradiation without changing the spectral distribution..

Calibration process Mil Std 810 G

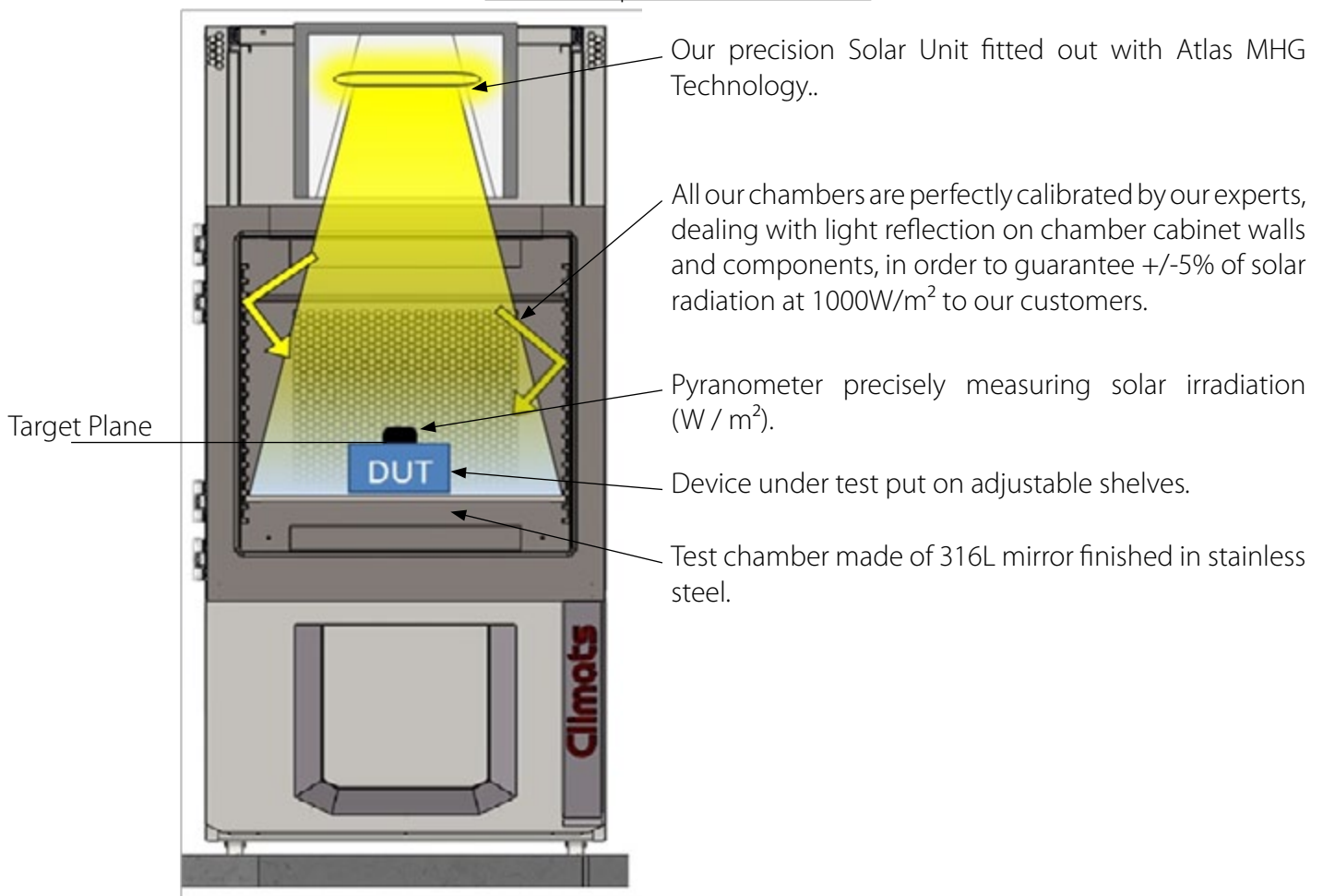

10/2015 - characteristics subject to change without notice and not contractual